

# Revealing Challenges for Automotive Interface Testing in the Application of Connectivity Systems

Dr. Alexander Prinz  
*BMW AG*  
Munich, Germany  
alexander.prinz@bmw.de

Hanxiang Zhu  
*BMW AG*  
Munich, Germany  
hanxiang.zhu@bmw.de

Alexander Gallasch  
*BMW AG*  
Munich, Germany  
alexander.gallasch@bmw.de

**Abstract:** This paper provides an overview of test methods for interface testing in Vehicular Connectivity Systems (VCS) using Cellular Vehicle-to-X (C-V2X) technology. After giving an introduction in the model-based test approaches in the field of automotive electronic control unit testing, we define a generic architecture for C-V2X applications. With the help of previous foundation, we identify the relevant components for Vehicle-to-Network (V2N) applications. Subsequently, we apply different test approaches based on simulation methods and test-interfaces as well as fleet-measurements. After analyzing the fleet data, we also consider the application of AI (Artificial Intelligence) based methods to optimize the performance and the reliability of the test results. In conclusion, we identify missing test approaches and -strategies and define optimizations for tooling, test-setups, data quality and measurement features for AI test-applications.

Automotive-Test, Design-for-Test, Test-Interface, Electronic Control Unit (ECU), Vehicle to X (V2X)

## 1 Introduction

X-in-the-loop (XiL) test methods are an inherent part of the test and development of electronic systems in the field of automotive production. Reference [FHW16] summarizes the constraints for the successful application of Hardware-in-the-loop (HiL) testing in the field of driver assistance systems:

- Closed-Loop HiL testing combines a real-time simulation with an unit-under-test (UuT). The test reaction of the electronic control unit is comparable to the real system behaviour. (e.g. behaviour inside the car)
- The injection describes the interface between simulation and UuT.
- For driver assistance, HiL-testing uses the injection on a hardware level and can be directly applied for e.g. sensor-testing. This means the sensor will be stimulated or the measured data will be provided to the control loop of the UuT using bus interfaces.
- The injection on the software level depends on the availability of interfaces in the software architecture of the UuT. The software-injection point has to ensure the real-time test operation on the HiL-test-bench.

The presented constraints are also transferable to other domains in the field of automotive electronic-control-units (ECU) like entertainment, power-train or suspensions. The sensors in the different application-fields might vary.

The so-called unit-under-test in the HiL-benches differs from the development phase of the vehicle project. Starting with component HiL-testing in an early stage, also the combination of several ECUs in a bundle will ensure that errors will be determined before system integration in the vehicle. The main drawback of bundle tests compared to single ECU-tests is the traceability of the error to the root cause. For that reason, the automotive industry has implemented interface-tests in its HiL-portfolio. In [Fil19] the main aspects of interface-testing are described:

- These interfaces are mostly communication interfaces between different ECUs that represent a vehicle function.
- When testing an interface one counterpart of the interface will be replaced by a simulation. Latter has to fulfill the requirements of real-time application, interface-stability and parameterization.
- The validation of interface-models can be more difficult than simulation-models of whole ECUs because repercussions can´t be eliminated every time and the availability of measurement data is not ensured in all processing layers.

To create the development of a safe driving environment, extensive testing is conducted throughout the different phases of a vehicle project. The keys to these innovative technologies are high safety, high efficiency, high reliability, and low latency. C-V2X is one such technology. It is a wireless technology which is utilized in autonomous driving and intelligent transportation systems (ITS), which entirely relies on communication systems, therefore, interface-testing is the ideal method to check and ensure its functionality.

V2X technology is actually not a recent concept. The establishment of standards of V2X was first proposed in 1999 by the US Federal Communications Commission (FCC) [FCC99]. In the first stage of this technological development, people attempted to achieve interconnectivity within a local area network using Dedicated short-range communications (DSRC) technology in the U.S. or ITS-G5 (Car2Car) in Europe, which is based on IEEE 802.11p. With the continuous development of communication technology, the emergence of LTE (Long-Term Evolution) greatly improved people’s lives. C-V2X was then born with it and is a 3rd Generation Partnership Project (3GPP) standard by using the fourth generation LTE (4G) or the fifth generation (New Radio 5G NR) connectivity for signal transmission and reception. This technology enables real-time communication and coordination between vehicles, infrastructure, pedestrians, and the network, ultimately contributing to a safer and more efficient transportation system. C-V2X can be divided into four types (see Figure 1) [MKOI18].

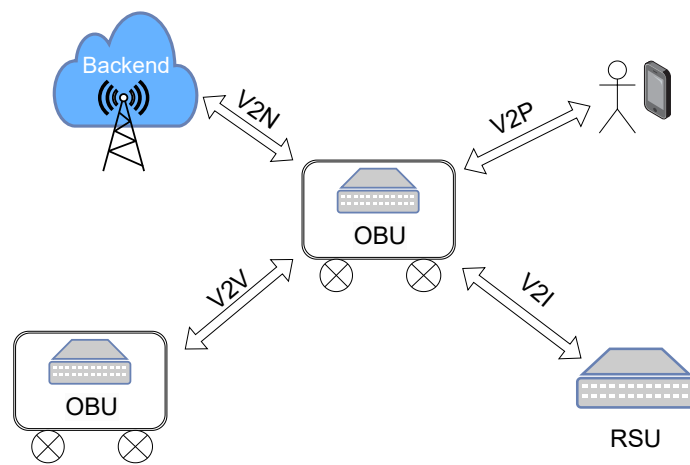

Figure 1: Applications of C-V2X

### 1.1 Device to device (D2D)

- V2V (Vehicle to Vehicle): Communication between vehicles to exchange the driving data, e.g., the distance between each other or the decision of lane changing.

- V2I (Vehicle to Infrastructure): Communication between vehicle and RSU (Road Side Unit) that the road infrastructure is connected with, e.g., traffic light, road sign and roadside sensors.
- V2P (Vehicle to Pedestrian): Communication between vehicle and pedestrian (their mobile devices) to remind both parties to pay attention to the traffic situation to avoid casualties.

For D2D, the communication is realized without utilizing the cellular network. The interface PC5 (Proximity Communication) at 5.9 GHz is used. It is a proximity Service which enables direct communication within a local region.

## 1.2 Device to network (D2N)

- V2N (Vehicle to Network): Communication between vehicle and backend to achieve better traffic efficiency through such as cloud services.

For D2N, cellular networks are used for V2N Applications. It is a Uu interface or also called a radio interface between the User Equipment (UE) and Node B. Node B is the cell tower better known as a base station.

## 2 Architecture of C-V2X

Figure 2 shows the scenario of the overall C-V2X system. "Connectivity" is the most important aspect here. Each unit is connected to at least one other unit. This is made possible by either wireless or wired connections and their underlying network protocols. In this chapter, the main components of the architecture as well as their interfaces are described.

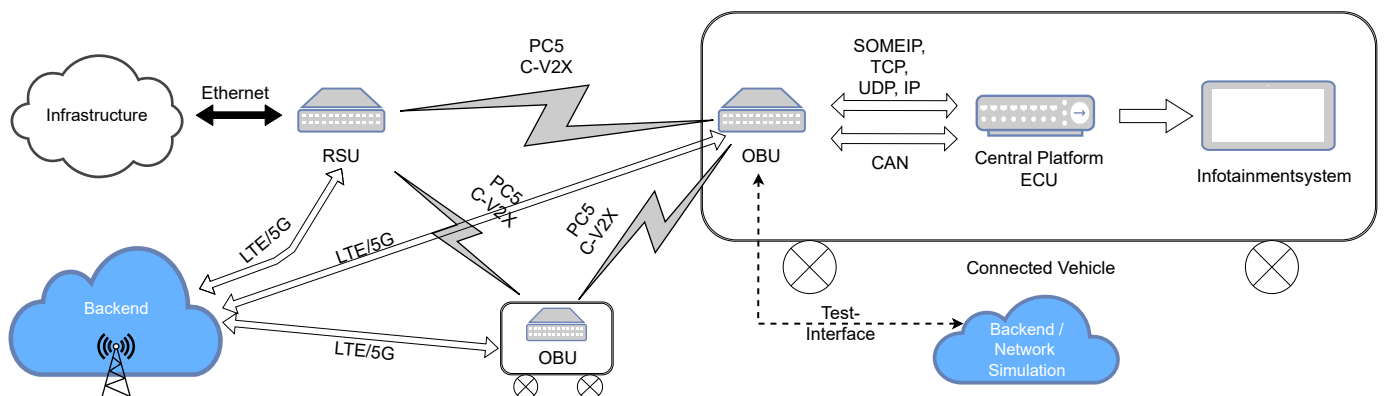

Figure 2: C-V2X System Architecture (with reference to [MVH21])

### 2.1 Roadside-Unit (RSU)

The RSU is a wireless transmitting device that enables sidelink communication (D2D) through the PC5 interface, eliminating the need for cellular networks. PC5 interface builds local communication within a short

range (max. 1 km). In this predefined area, the RSU can broadcast real-time information from the connected units (infrastructure like traffic lights) to vehicles. Additionally, if an eSIM-card (embedded Subscriber Identity Module) is integrated in the RSU, the data can also be transmitted directly over the cellular network [[MVH21](#)].

## 2.2 On Board Unit (OBU)

The OBU is a wireless communication device installed in vehicles. With the OBU, the performance of autonomous driving can be significantly improved through direct communication between the vehicle's OBU and RSUs, as well as other OBUs. The most important information, such as the vehicle's location, direction, and speed, is sent and received here.

C-V2X can address all possible connectivity challenges. Sidelink communication over the PC5 interface ensures low latency and spatial resource reuse within the local field. Outside its local coverage, the Uu interface via LTE/5G bridges the gaps and aids in more efficient centralized control [[GAA18](#)]. Combined with autonomous driving systems (Data Analysis from Camera, LiDAR, Radar, GNSS, etc.), C-V2X can solve many challenges encountered during driving: platooning (maintaining a safe distance between platoons of vehicles), extended sensors (exchange of sensor data), advanced driving (semi-automated or fully-automated driving), and remote driving (drive for disabled passenger or in dangerous environment) [[TrGPP18b](#)]. In this paper, V2N communication via the Uu interface is focused on automobile connectivity, such as entertainment services.

To realize V2N communication, an OBU integrated with an eSIM card is a prerequisite. By connecting a small single-board computer with an LTE module, we have built our own OBU device and controlled it to test connectivity while the vehicle is in motion. Doppler shift was not considered because the driving speeds were approximately within 120 kilometers per hour (km/h) where LTE network performance can be considered unaffected if speeds are below 120 km/h [[TrGPP12](#)]. As the vehicle is not in a static position, the connected base station/Node B is changing over time for real driving scenarios. Therefore the connected vehicle experiences varying network quality and speed rates.

## 3 Interface- and Function-Testing by example of V2N

This chapter contains various aspects of the development, testing and launch of connected vehicles based on V2N-technology. Each method has various scopes and, therefore, contributes differently to the functionality and quality of connected services. As V2N-connection quality and data rates are important for the development of connected vehicles, we describe V2N-traffic simulations (HiL) for the early development phase. The testing goals, including functional and stress tests, will be taken into account. In the second step, the V2N-System will be launched and LTE-raw-data from real traffic scenarios will be evaluated. In the end, high-level V2N-data-rates will be analyzed. The quality of the collected data will be considered for applications like big data and artificial intelligence model approaches. The ultimate goal in future work is to achieve a V2N-network speed and quality model to promote and maintain the development of connected vehicles that rely on V2N-technology.

### 3.1 V2N-Traffic Functional and Stress Test Simulation

As a first step, the presented electronic control units in the connected vehicle, as shown in Figure 2, were tested in a HiL-setup. To fulfil functional as well as stress tests, we considered a simulated V2N connection for flexibility. The network simulation is connected to the OBU-system with the test-interface in Figure 2. It includes an interpreted network communication model based on OSI-Layer four up to seven. When running the test-setup, different requests and responses were triggered by the simulation, and the OBU received and interacted with the simulated backend / network-simulation with the given test-interface. Metrics such as jitter and latency for repetitive request-response communication, packet loss for high-frequency request queues, and connection loss can be evaluated in different simulated communication scenarios for the V2N vehicle (see Figure 3). The evaluation was implemented with a self-developed software. Latter already includes a framework for some of the required transport protocols and is easily adapted and modified to support application specific protocols. It delivers an illustrated test report, which gives the tester a quick overview of performance and results.

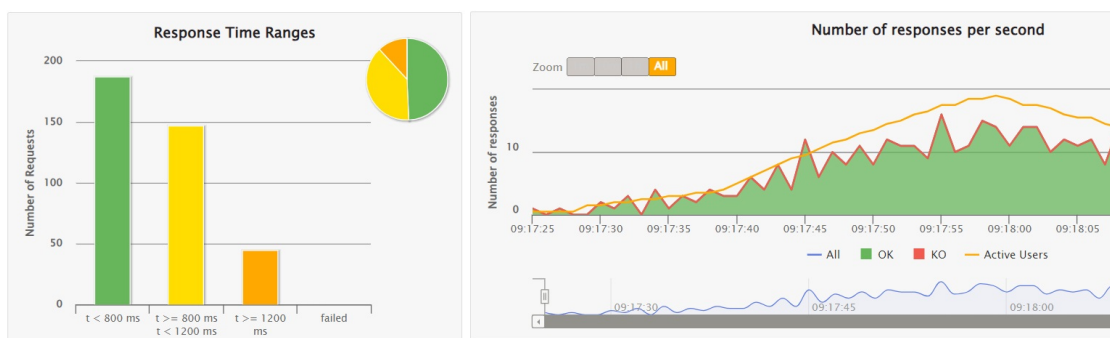

Figure 3: Report and metrics for response times from the V2N-Traffic HiL-Test

### 3.2 V2N-Measurement and Evaluation for OBU

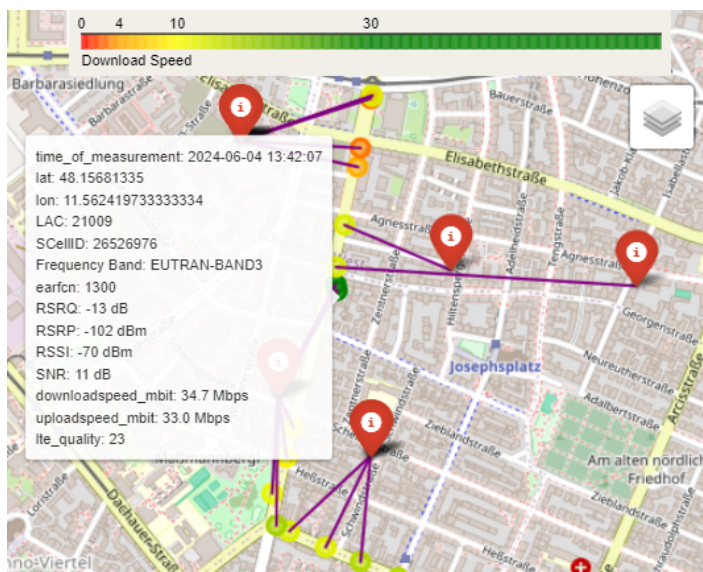

Figure 4: V2N-Traffic Data Analysis: Tower-Assignment and LTE-Raw Data. MNO: DE-Telekom

Beside simulation, also real vehicle measurements, with reference to the measurement setup in Figure 2, will be elaborated. The hardware part consists of LTE communication devices made up of components Raspberry Pi 4 integrated with a GPS antenna, and the Simcom Sim7600X (LTE Module) as the OBU. The selected MNO (Mobile Network Operator) is DE-Telekom. In different scenarios, we conducted multiple tests specifically targeting V2N communication:

- An urban route with the best infrastructure
- An inter-district urban route with moderate infrastructure
- A long-distance route with weaker infrastructure

In Figure 4, a static measurement in an urban area was considered. The visualized LTE-Raw data provides an overview of the parameters which reflect the overall quality of the current signal. The most important values here are RSSI (Received Signal Strength Indicator), RSRP (Reference Signal Received Power), RSRQ (Reference Signal Received Quality), and SNR (Signal-to-noise ratio). Besides the SNR value, they depend on each other sequentially. RSSI assesses the average total received power observed within the measurement bandwidth across N resource blocks (RBs). This power indicated by the carrier RSSI encompasses contributions from co-channel serving and non-serving cells. RSRP represents the power of the LTE Reference Signals distributed across both the full bandwidth and narrowband. Generally, the RSRP value determines which base station the LTE module will connect to. RSRQ is a C/I (Carrier-to-Interference) type of measurement and reflects the quality of the received reference signal. The RSRQ measurement provides supplementary information when RSRP alone is insufficient for cell reselection decisions [PBM<sup>+</sup>21] [AM17].

The circles represent the positions where we conducted our tests. Depending on upload and download data rates tested in megabits per second (Mbps), they are assigned different colours (as seen at the top of Figure 4). The connected 4G base stations (red pin needles) are found with the help of detected cell ID (SCellID) and are linked to these positions by purple line segments. The switches between different cell towers can be observed in the Figure 4. The key requirement for connected apps and services inside the vehicle is to prevent time-limited failures. For entertainment services, for example, the required buffers have to be sufficiently large to provide seamless usage. The requirements can be derived with big-data fleet analysis to be aware of the worst-case scenarios. Using the real data we collected, we conducted a detailed analysis. During the initial check of the data's validity, we already found significant discrepancies, which led to a loss of accuracy. Due to the importance of the RSRP value described earlier, it was analysed first versus the RSSI value on which it depends (Equation 2). A linear relationship between the two values is to be expected since both units are logarithmic, and N remains constant because the channel bandwidth has not changed according to the recorded data. However, what we discovered through the data is that the RSRP values fluctuate by  $\pm 10$  dBm for each RSSI value, which makes it scientifically unusable. It could be due to the Sim7600H hardware not always functioning stably, resulting in the data not always being scientifically accurate, which is also noticeable when we compare the LTE quality values with the RSSI values. According to 3GPP [TrGPP18a], the two are always clearly defined in relation to each other, which is not reflected in the recorded data.

### 3.3 V2N-Network Speed-Test Verification and Elaboration of the data quality for AI-Applications

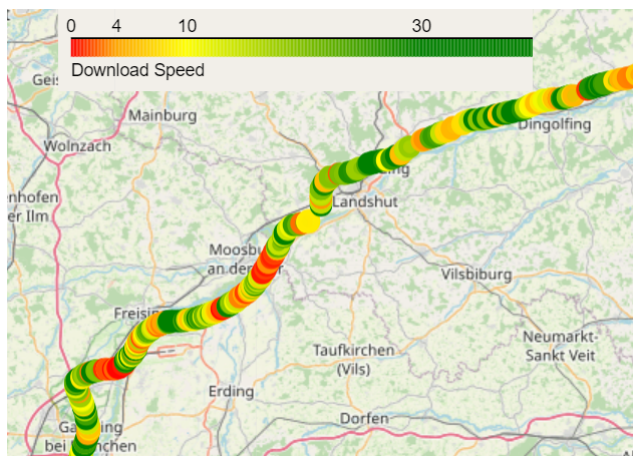

Figure 5: V2N-Traffic Data Analysis: Download-Speed over Driving-Position. MNO: DE-Telekom

After the collection of raw data and further processing have been finished, the following features became available (See Table 1), which we have used to train an AI model to predict the stability of a V2N system. Three different algorithms have been chosen, which are listed in Table 2. Even though we used the same inputs as those in some published works [ATSM<sup>+</sup>23] [EAAz<sup>+</sup>], we were not able to reproduce their results. The accuracy of both models we trained using KNN and RF with Grid Search was around 66%. What has already been noticed during the research is that there is no clear scientific solution to consistently predict LTE network performance. The selected models in these two example papers produced very different results. The possible reasons for this phenomenon

could be the significant differences in 4G/5G infrastructure across different regions and the individual differences in LTE modules produced by various companies. We believe that more importantly, additional features are needed for more accurate learning and prediction, which are listed in Table 3. The first also the most important one is every RSRP value of available surrounding eNodeBs which is not only needed for understanding the feasibility of V2N on different road segments but also for calculating approximate SINR values that provide a more accurate reflection of the actual network environment [DBT15]. There are many LTE Modules on the market that have the capability to obtain the RSRP values of four dominating surrounding eNodeBs, which is unfortunately not our case. Cell load also plays a role, varying depending on the time of day. If the load exceeds 70%, the signal quality will deteriorate [SVY06]. A complete digital twin can be considered as the ultimate goal that many fields aim to achieve. Details like signal reflections or wall penetration can be accurately simulated to ensure theoretical plans become a reality. A famous ongoing project is Nvidia’s Aerial Omniverse Digital Twin [Cor24].

Table 1: Overview of the available parameters in V2N-Measurement data.

Available Features	Description
Radial distance to eNodeB	The absolute distance between the measurement point and eNodeB, where eNodeB is LTE base station.
RSSI	$RSSI \text{ (dBm)} = 10 \cdot \log_{10} \left( \frac{P(\text{mW})}{1\text{mW}} \right) \text{ (1)}$
RSRP	$RSRP \text{ (dBm)} = RSSI \text{ (dBm)} - 10 \cdot \log_{10}(12 \cdot N) \text{ (2)}$
RSRQ	$RSRQ \text{ (dB)} = 10 \cdot \log_{10}(N) + RSRP(\text{dBm}) - RSSI(\text{dBm}) \text{ (3)}$ where $N$ is the number of resource blocks (RBs) as per channel bandwidth
SNR	$SNR \text{ (dB)} = 10 \cdot \log_{10} \left( \frac{P_{\text{signal}}}{P_{\text{noise}}} \right) \text{ (4)}$
Upload rate (Mbps)	Measurement of the average performance of the internet connection by calculating the upload speed between the device and the selected server
Download rate (Mbps)	See upload rate above

Table 2: Overview of used AI-Algorithms with reference to [HTF09]

Used algorithms	Description
K-Nearest Neighbors (KNN)	KNN classifies an instance by analyzing the labels of the k closest data points in the feature space.
Random Forest (RF) with GridSearchCV	RF combines the predictions of multiple decision trees, each built on a different subset of the training data. GridSearchCV uses cross-validation to choose the best one.
Neural Network (NN)	NN consists of multiple layers of neurons with activation functions, learning from data through forward and backward propagation, adjusting weights to minimize error.

Table 3: Overview of the required parameters in V2N-Measurement data. (Design-for-Test)

Required Features	Description
Available eNodeBs	The corresponding RSRP values of available surrounding eNodeBs.
Signal-to-interference-plus-noise ratio (SINR)	According to the research in [DBT15], with corresponding RSRP values of available surrounding eNodeBs, SINR can be well approximated.
Cell load	The performance of cells at different time intervals.
3-D environment model	A complete digital twin of infrastructure and construction.

## 4 Conclusion

Summing up above, the testing of V2N-technology for connected vehicles is challenging and requires various test-solutions and data-analysis. First, we have proposed an approach for HiL-based functional and stress testing, which requires suitable design-for-test interfaces, simulation models and test-automation. Then, we have discussed various V2N-vehicle fleet data. We elaborated that the LTE-raw data could not be verified with the given physical dependencies. This could have it's root cause to measurement-effects that were not considered so far, such as cell load, construction layout of nearby buildings, weather, and other disturbing factors. In the end, the evaluation of the V2N network speed over a long driving period provides a good overview of the overall vehicular connectivity performance. These measurement data were used for training AI algorithms, as shown in Table 2. The currently achieved data quality and amount were not sufficient for a successful application to predict download- and upload-rates. Future work will focus on the repeatability and stability of LTE raw data and download- and upload-rates. This supports the development of future applications for vehicular connectivity, as a seamless connection with high data rates is mandatory at all times.

## Acknowledgment

At this point we appreciate the collaboration of all colleagues that worked on this project. Namely, we thank Sebastian Buresch; BMW AG, Jonas Schmitz; BMW AG and Julian Wiesner; BMW AG for their effort.

## References

- [AM17] Nadia Awad and Is-Haka Mkwawa. The impact of the reference signal received power to quality of experience for video streaming over LTE network. *2017 Annual Conference on New Trends in Information & Communications Technology Applications (NTICT)*, pages 192–196, 2017.
- [ATSM<sup>+</sup>23] A. Al-Thaedan, Z. Shakir, A. Y. Mjhood, et al. Downlink throughput prediction using machine learning models on 4G-LTE networks. *International Journal of Information Technology*, 2023.
- [Cor24] Nvidia Corporation. NVIDIA Aerial Omniverse Digital Twin. <https://developer.nvidia.com/aerial-omniverse-digital-twin>, 2024. [Online; accessed 18-August-2024].

- [DBT15] Milutin Davidovic, Sanja Bjekovic, and Igor Tomic. On the impact of network load on LTE network downlink performance. 06 2015.
- [EAAz<sup>+</sup>] Habiba Elsherbiny, Hazem M. Abbas, Hatem Abou-zeid, Hossam S. Hassanein, and Aboelmagd Noureldin. 4G LTE Network Throughput Modelling and Prediction. In *GLOBECOM 2020 - 2020 IEEE Global Communications Conference*.
- [FCC99] FCC Federal Communications Commission. FCC ALLOCATES SPECTRUM IN 5.9 GHz RANGE FOR INTELLIGENT TRANSPORTATION SYSTEMS USES Action Will Improve the Efficiency of the Nation's Transportation Infrastructure. [https://transition.fcc.gov/Bureaus/Engineering\\_Technology/News\\_Releases/1999/nret9006.html](https://transition.fcc.gov/Bureaus/Engineering_Technology/News_Releases/1999/nret9006.html), 1999. [Online; accessed 22-December-2023].
- [FHW16] Marius Feilhauer, Juergen Haering, and Sean Wyatt. *Current Approaches in HiL-Based ADAS Testing*, volume 9. 2016.
- [Fil19] Thies Filler. *Entwicklung einer Methodik für die durchgängige Integration von Hardware und Softwaremodellen in Simulationen für Fahrfunktionen*. Springer-Verlag, Berlin Heidelberg New York, 2019.
- [GAA18] 5GAA 5G Automotive Association. Cellular-Vehicle-to-Everything (C-V2X): today and next steps. [https://www.gsma.com/iot/wp-content/uploads/2020/07/02\\_5GAA\\_Maxime-Flament.pdf](https://www.gsma.com/iot/wp-content/uploads/2020/07/02_5GAA_Maxime-Flament.pdf), 2018. [Online; accessed 13-January-2024].
- [HTF09] Trevor Hastie, Robert Tibshirani, and Jerome Friedman. *The Elements of Statistical Learning: Data Mining, Inference, and Prediction*. Springer Series in Statistics. 2 edition, 2009.
- [MKOI18] Zachary MacHardy, Ashiq Khan, Kazuaki Obana, and Shigeru Iwashina. V2X Access Technologies: Regulation, Research, and Remaining Challenges. *IEEE Communications Surveys and Tutorials*, 20(3):1858–1877, 2018.
- [MVH21] Lili Miao, John Jethro Virtusio, and Kai-Lung Hua. PC5-Based Cellular-V2X Evolution and Deployment. *Sensors*, 21:843, 2021.
- [PBM<sup>+</sup>21] Gubtha Mahendra Putra, Edy Budiman, Yonatan Malewa, Dedy Cahyadi, Medi Taruk, and Um-mul Hairah. 4G LTE Experience: Reference Signal Received Power, Noise Ratio and Quality. In *2021 3rd East Indonesia Conference on Computer and Information Technology (EIconCIT)*, pages 139–144, 2021.
- [SVY06] Iana Siomina, Peter Varbrand, and Di Yuan. Automated optimization of service coverage and base station antenna configuration in UMTS networks. *IEEE Wireless Communications*, 2006.
- [TrGPP12] 3GPP The 3rd Generation Partnership Project. 3GPP TS 36.300 version 9.9.0 Release 9, 2012.
- [TrGPP18a] 3GPP The 3rd Generation Partnership Project. 3GPP TS 27.007 version 15.2.0 Release 15, 2018.
- [TrGPP18b] 3GPP The 3rd Generation Partnership Project. Study on Enhancement of 3GPP Support for 5G V2X Services. [https://www.3gpp.org/ftp/Specs/archive/22\\_series/22.886/](https://www.3gpp.org/ftp/Specs/archive/22_series/22.886/), 2018. [Online; accessed 13-January-2024].